

# Air Freight Container Sizes



Air containers are also known as Unit Load Devices, or ULDs and have a 3 letter code

The first letter indicates container type: A=container P=pallet R=thermal certified

The second letter indicates base dimensions: A=2.23 x 3.17 L=1.53 x 3.17 K=1.53 x 1.56

The third letter indicates other technical information such as whether the container contains forklift slots

This information is a guide only. Actual dimensions and capacities differ between manufacturers and airlines.

There are multiple other container sizes not listed here

Code	Description	Volume (m <sup>3</sup> )	Payload (kg)	Tare (kg)	Length (m)	Width (m)	Height (m)	Aircraft
<b>AA2/AAP</b>	LD9 Full size lower deck container	10.6	4 898	200	3.18	2.24	1.63	B767 B777 A330
<b>ALN</b>	LD8 Full width lower deck container	6.85	2 282	168	3.15	1.53	1.63	B767
<b>AVE/AVN/AKE/AKN</b>	LD3 half size lower deck container	4.13	1 526	62	1.98	1.53	1.63	A330 B777
<b>AKG/AKH</b>	LD3 Lower deck container	3.68	1 045	90	2.42	1.53	1.14	A320 A321
<b>PMC</b>	LD7-96 Lower deck pallet and net	11.7	5 098	120	3.07	2.34	1.6	B767 B777 A330
<b>PAP/PAG</b>	LD7-88 Lower deck pallet and net	10.76	4 490	110	3.07	2.08	1.6	B767 B777 A330
<b>PKC</b>	LD3-45 wing pallet and net	3.68	1 061	74	2.42	1.53	1.14	A320 A321

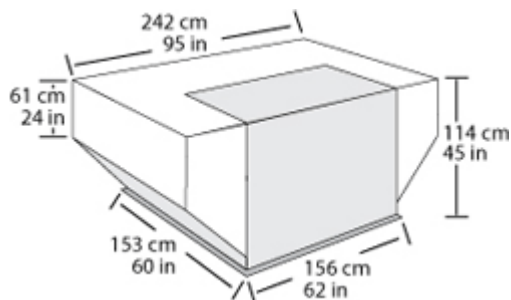

AKG

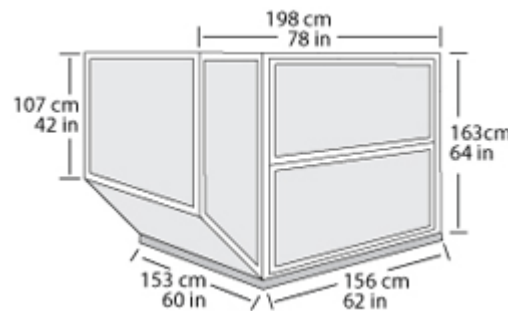

AVE AVN AKE AKN

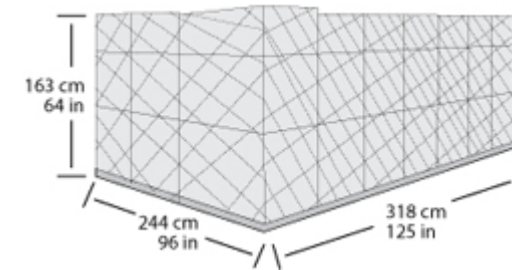

PAP PAG PMC

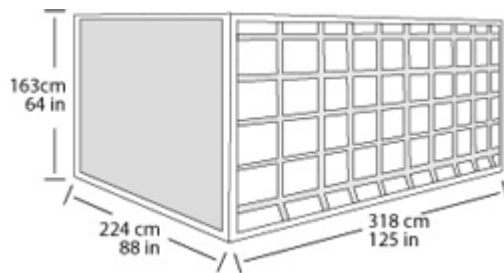

AA2 AAP

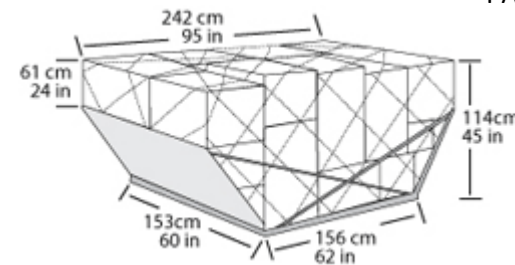

PKC